

# INSTRUMENT CURRENT TRANSFORMER

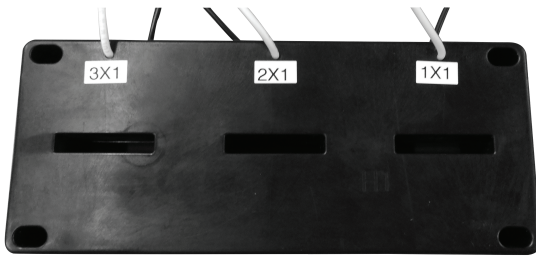

## 3P 1.55" x 0.25" Rectangular Window

Width 2.00"



- Application - 3 Phase CT for Metering
- Frequency 50 - 400hz
- Insulation Class 0.6kV, 10kV BIL full wave
- Other ratios available upon request
- Rating Factor: 1.33 @ 30C ambient
- Secondary leads are UL 1015 105 C, #16 AWG, 8.25" long
- Approximate weight 5 lbs
- UL and cUL Certified per ANSI/IEEE C57.13 standard



### ELECTRICAL SPECIFICATIONS

CATALOG NUMBER	CURRENT RATIO (A)	ANSI METERING CLASS AT 60HZ					SECONDARY WINDING RESISTANCE(OHMS @75C)
		B0.1	B0.2	B0.5	B0.9	B1.8	
ICT32001	600:5	0.3	0.3	0.6	0.6	0.6	0.13

### MECHANICAL SPECIFICATIONS

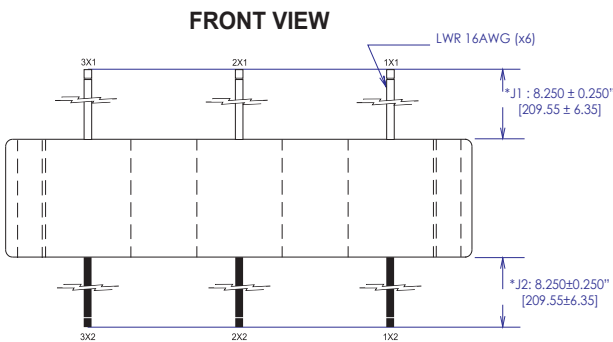

Insulation class 600V, 10KV BIL  
Frequency 50-400 Hz.  
Continuous current rating factor:  
- 1.33 at 30°C ambient  
- 1.00 at 55°C ambient

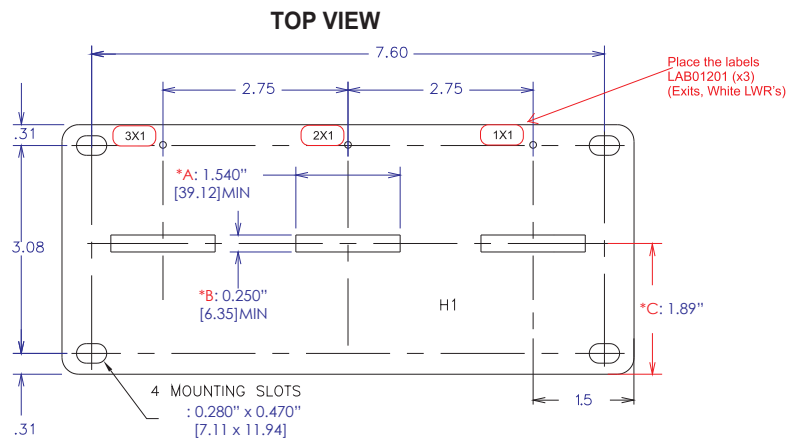
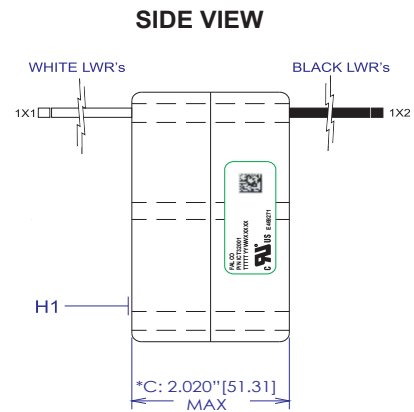

### SCHEMATIC

