

6.5" Internal Diameter, Multi-Ratio
Width 3.38"



- Application - Relay and Metering
- Frequency 50 - 400hz
- AC capability 600 - 4000 Amperes
- Insulation Class 0.6kV, 10kV BIL full wave
- Excitation curves upon request
- Secondary terminals are brass screws No. 10-32 with one flatwasher, lockwasher, accessible from either side
- Approximate weight 24 lbs
- UL and cUL Certified per ANSI/IEEE C57.13 standard

C US E469271

ELECTRICAL SPECIFICATIONS

CATALOG NUMBER	CURRENT RATIO (A), (X1-X5)	RELAY CLASS	ANSI METERING CLASS AT 60HZ					SECONDARY WINDING RESISTANCE(OHMS @75C)	CURRENT RATING FACTOR @30C
			B0.1	B0.2	B0.5	B1.0	B2.0		
ICT91A20	600:5	C100	0.3	0.3	0.3	0.6	0.6	0.19	2.0
ICT91A21	1200:5	C200	0.3	0.3	0.3	0.3	0.3	0.42	2.0
ICT91A06	2000:5	C200	0.3	0.3	0.3	0.3	0.3	0.53	2.0
ICT91A09	3000:5	C200	0.3	0.3	0.3	0.3	0.3	0.68	2.0
ICT91A03	4000:5	C200	0.3	0.3	0.3	0.3	0.3	0.96	1.5

MECHANICAL SPECIFICATIONS

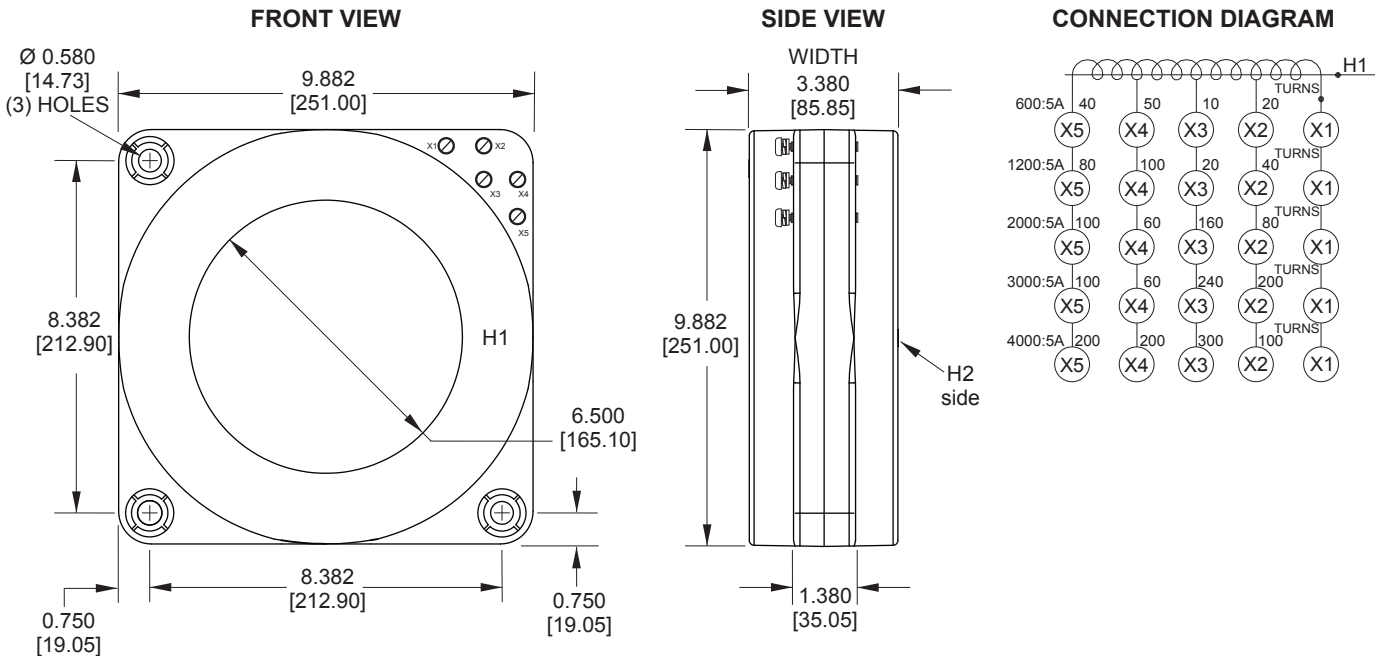

DIMENSIONS IN INCHES[MM]