

# INSTRUMENT CURRENT TRANSFORMER



6.5" Internal Diameter  
Width 6.75"



- Application - Relay and Metering
- Frequency 50 - 400hz
- AC capability 75 - 4000 Amperes
- Insulation Class 0.6kV, 10kV BIL full wave
- Other ratios available upon request
- Secondary terminals are brass screws No. 10-32 with one flatwasher, lockwasher, accessible from either side
- Approximate weight 52 lbs
- UL and cUL Certified per ANSI/IEEE C57.13 standard



## ELECTRICAL SPECIFICATIONS

CATALOG NUMBER	CURRENT RATIO (A)	RELAY CLASS	ANSI METERING CLASS AT 60HZ					SECONDARY WINDING RESISTANCE(OHMS @75C)	CURRENT RATING FACTOR @30C
			B0.1	B0.2	B0.5	B1.0	B2.0		
ICT92007	50:5	C10	1.2	2.4				0.03	2.0
	75:5	C20	1.2	1.2	2.4			0.04	2.0
ICT92004	100:5	C20	0.6	1.2	2.4			0.05	2.0
ICT92005	150:5	C50	0.6	0.6	1.2	2.4		0.11	2.0
ICT92001	200:5	C50	0.3	0.3	0.6	1.2	2.4	0.11	2.0
	250:5	C50	0.3	0.3	0.6	1.2	2.4	0.15	2.0
	300:5	C100	0.3	0.3	0.3	0.6	1.2	0.15	2.0
ICT92009	400:5	C100	0.3	0.3	0.3	0.6	0.6	0.21	2.0
ICT92012	500:5	C100	0.3	0.3	0.3	0.3	0.6	0.24	2.0
ICT92003	600:5	C200	0.3	0.3	0.3	0.3	0.6	0.39	2.0
ICT92013	800:5	C200	0.3	0.3	0.3	0.3	0.3	0.44	2.0
ICT92014	1000:5	C200	0.3	0.3	0.3	0.3	0.3	0.48	2.0
ICT92002	1200:5	C400	0.3	0.3	0.3	0.3	0.3	0.75	2.0
	1500:5	C400	0.3	0.3	0.3	0.3	0.3	0.87	2.0
ICT92006	2000:5	C400	0.3	0.3	0.3	0.3	0.3	0.75	2.0
	2500:5	C400	0.3	0.3	0.3	0.3	0.3	0.86	2.0
	3000:5	C400	0.3	0.3	0.3	0.3	0.3	1.65	1.3
ICT92018	4000:5	C400	0.3	0.3	0.3	0.3	0.3	1.32	1.3

## MECHANICAL SPECIFICATIONS

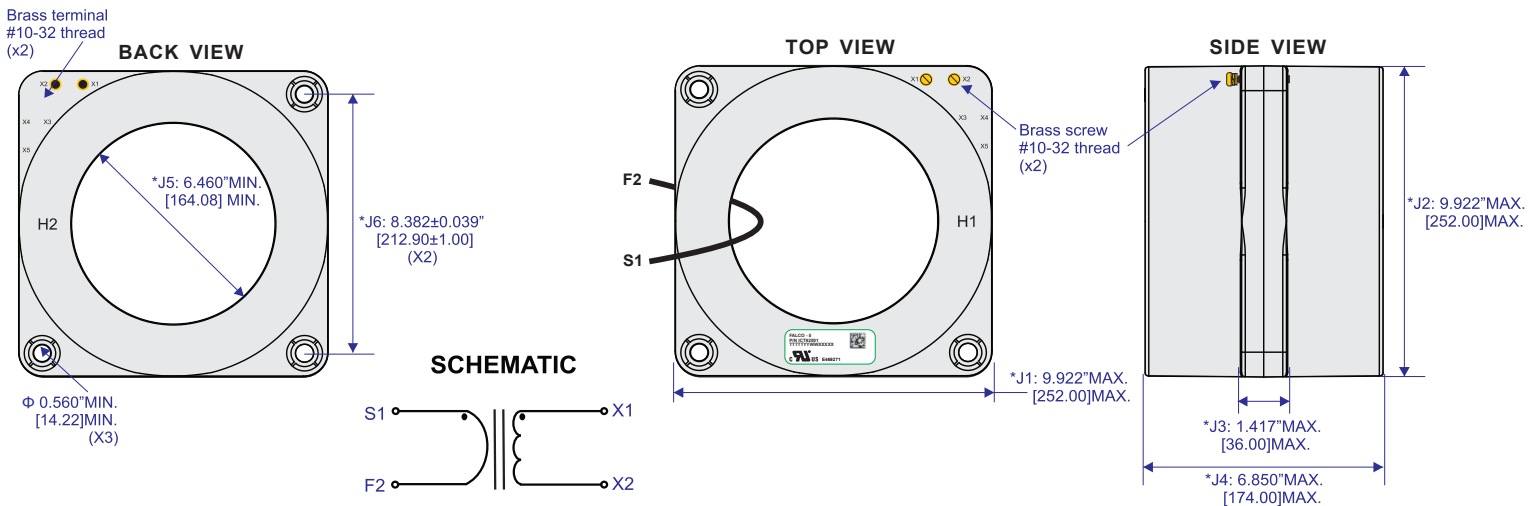

6.5" Internal Diameter  
Width 3.38"



Typical Excitation Curves

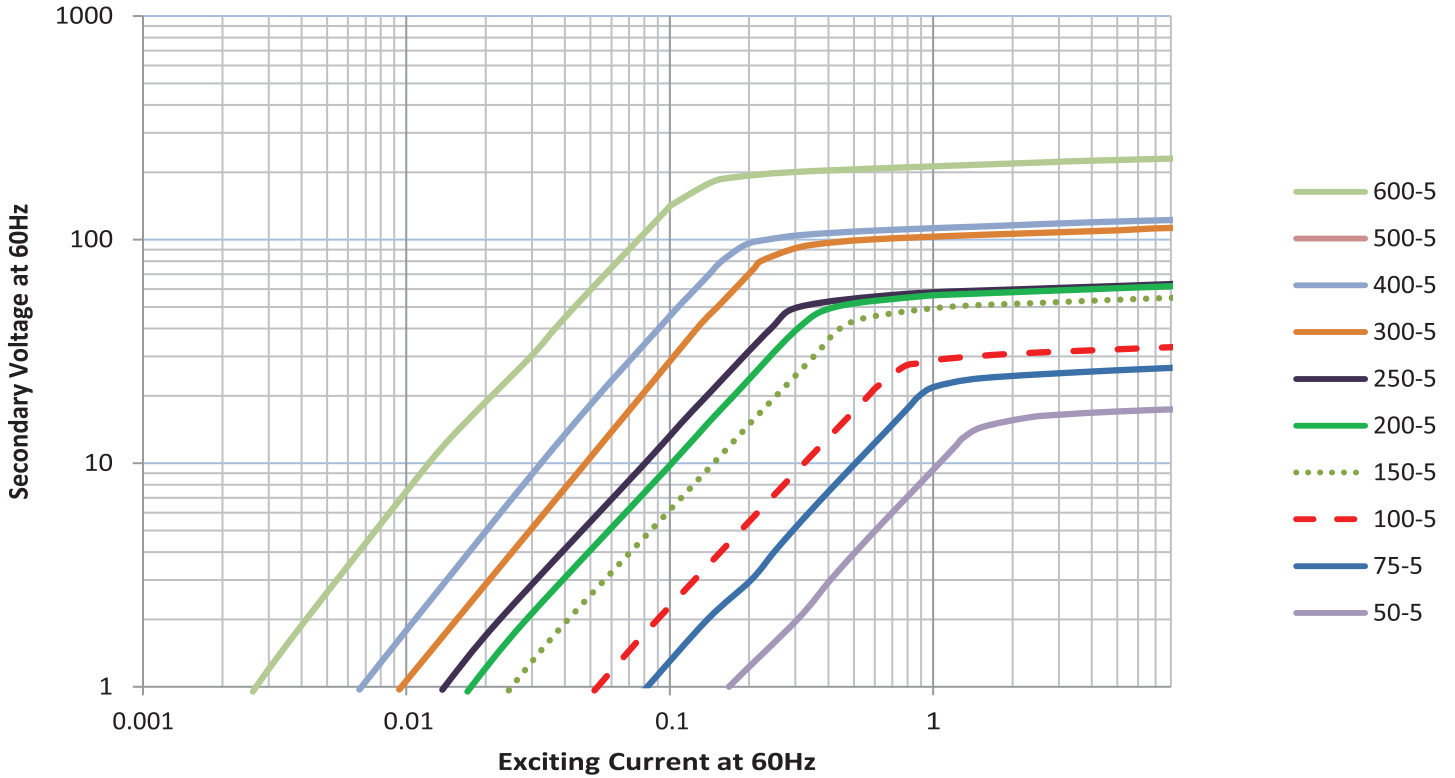

Typical Excitation Curves

